

# EYE-E37

650TVL, 3.6MM FIXED LENS  
25-30M IR RANGE, 36PCS IR LED

Armoured Housing



Day & Night



IP66



Dual Ring Design



ATR



Auto Gain Control



Auto White Balance



3-Axis Gimble



Electric Shutter



25-30M IR Range



## EYE-E37-FG SPECIFICATIONS

CCD	1/3" 960H Exview HAD II CCD
DSP	Enhanced Effio-E
TVL	COLOR: 650TVL , B/W: 700TVL
Lens	2.8-12mm Varifocal
IR Range	25-30M
IR Leds	36 PCS
Minimum Illumination	0 Lux (IR ON)
Signal to Noise Ratio	52dB (AGC OFF)
Gamma Correction	0.45
Video Output	1Vp-p,75Ω
Effective Pixels	PAL: 976 (H) × 582 (V) , NTSC: 976 (H) × 494 (V)
Auto Electric Shutter	PAL:1/50-1/100,000S NTSC:1/60-1/100,000S
White Balance	ATW/PUSH/USER1/USER2/ANTI CR/ MANUAL/PUSH LOCK
Back Light Compensation	BLC & HSBLC & ATR (Adaptive Tone Reproduction)
Day/Night	Auto/COLOR / B&W / Infrared LED exposure optimization
Motion Detection	ON/OFF(24*16 Zone)
Privacy Masking	ON / OFF (8 Marks)
IR Led	36 PCS
IR Range	25-30M
Menu	OSD Control
S/N Ratio	52dB (AGC OFF)
Automatic Gain Control	AUTO (4 STEP)
Dynamic Noise Reduction	2D-NR
IP Rating	IP66
Power Supply	DC12V±20%
Scanning System	2:1 Interlace
Current Consumption	105mA (IR OFF) , 345mA ( IR ON )
Storage Temperature	-20~+60°C
Operating Temperature	-10~+50°C
Dimensions	120×86mm
Weight	800g

## GENERAL FEATURES

- Internal/External
- Auto White Balance
- Colour/Mono
- Armoured Housing
- 3-Axis Gimble
- Dual ring design (No IR reflection)
- Screw base, simple install
- Day and night
- Privacy masking
- Motion Detection
- 2DNR
- ATR (Adaptive Tone Reproduction)
- 25-30M IR Range

## DIAGRAM

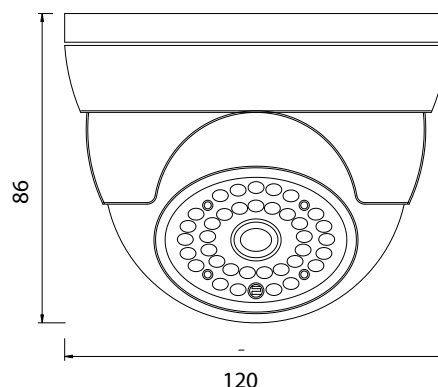

## DIMENSIONS

120mm x 86mm

## COLOUR

GREY

# EYE-E37

## KEY FEATURES

### 2D-NR



#### 2D-NR (2-DIMENSIONAL DIGITAL NOISE REDUCTION)

Removes the noise in low intensity illumination environment and reproduces the better and clearer image qualities.

### ATR



#### (ATR) ADAPTIVE TONE REPRODUCTION

ATR improves the visibility of the entire picture by providing the optimum gradation compensation.

### HLC



#### HLC - HIGH LIGHT COMPENSATION

Detects bright highlights and masks them out in order to reveal detail which would otherwise be obscured by the flare effect from a strong light source, such as a torch light or car headlights.

### INTELLIGENT IR



#### INTELLIGENT IR

The camera automatically adjust the infrared light required, as the subject moves closer to or further away from the camera, this results in a clear image that is not washed out or too dark.

### BLC

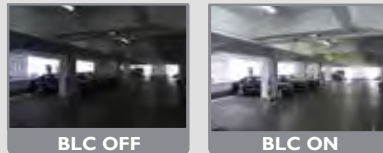

#### (BLC) BACK LIGHT COMPENSATION

This function makes objects in front of a bright scene (such as a window on a bright sunny day) clearer to see by increasing their brightness and making the background darker.

### AGC



#### (AGC) AUTOMATIC GRAIN CONTROL

When the viewed scene's light level falls below a usable threshold, AGC activates and boosts the signal in order to retain usable illumination.

AVAILABLE IN  
WHITE BLACK & GREY

