

GuardCam

Combined security camera floodlight system



Table of contents

Contents of package	3
GuardCam Motion Light with Video Camera	4
Step 1 - Assembly	4
Step 2 - Insert/remove SD Card	5
Step 3 - Installing the GuardCam	5
Step 4 - Mounting the GuardCam	6
Step 5 - Adjusting the settings	7
Step 6 - Set the Date and Time	9
Step 7 - Viewing video	10
Technical Specifications	10
General Information and Safety	11

Contents of package



GuardCam Motion Light
with Video Camera



User Manual



230W halogen light bulb



1 x Allen key
2 x screws
2 x plastic masonry plugs



2G SD card



SD card reader

GuardCam Motion Light with Video Camera overview

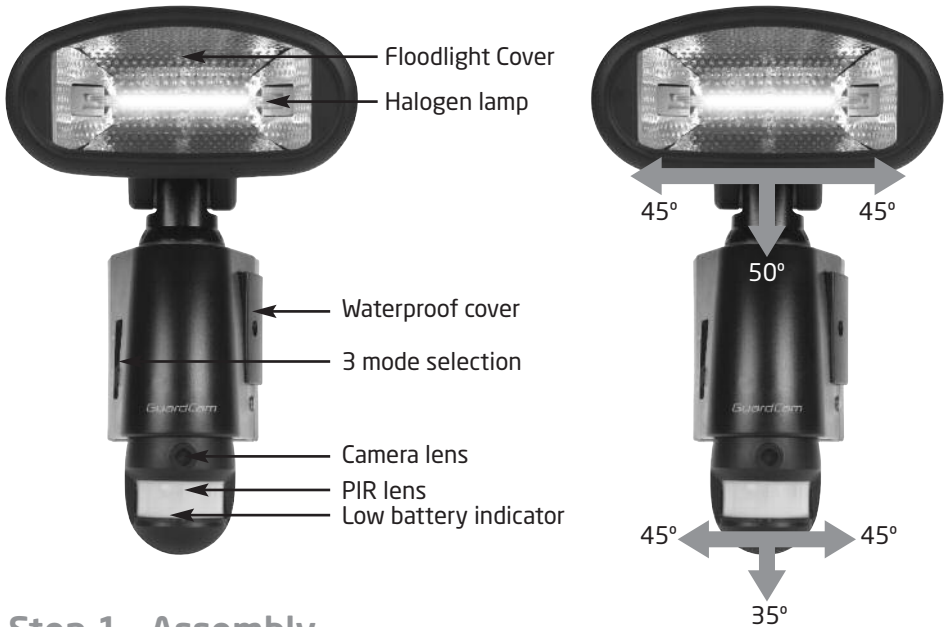

Step 1 - Assembly

Install/replace the halogen lamp (see Fig. 1)

- Make sure to unplug unit or turn off power first.
- Remove floodlight cover by unscrewing floodlight screws using a Phillips head screw driver.
- If replacing a bulb, take out the existing halogen light bulb.
- Put in new 230 Watt maximum halogen light bulb.
- Replace floodlight cover tightening screws carefully.

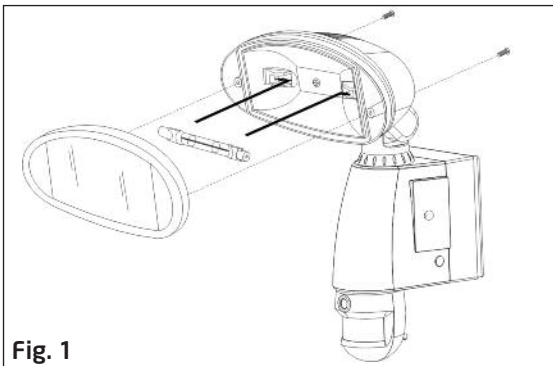

Fig. 1

Installation and replacement of back up batteries

The Function of the back up batteries is to Provide power to complete a part finished recording if a mains power outage occurs and preserve date/time settings for a minimum of 120 hours prior to mains power being restored.

Unscrew the screw A and remove back cover. Unscrew screw B and remove battery cover.

- Put the 3pcs "AAA" 1.5V batteries into the battery compartment and make sure the polarity (- +) is aligned correctly.
- Replace battery cover and back cover, tightening screws carefully.
- Note: To guard against damage from battery leakage it is good practice to replace batteries on a yearly basis .
- To maintain battery back up function please replace batteries after a total of 120 hours of mains power failure.

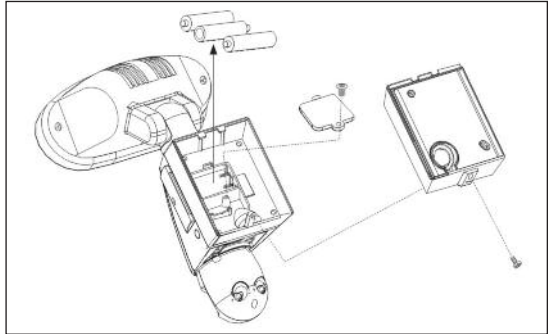

Step 2 - Insert/remove SD card (see Fig. 2)

- Unscrew the waterproofed cover using provided Allen key, then insert the SD card until it automatically locks into place.
- If you need to remove the SD card, please press OFF button and take it out within 30 seconds.
- When LED light turns green, meaning SD card is being read, do not remove SD card or data may be lost.
- To remove SD card, push in SD card to eject. Once to unlock then pull out.

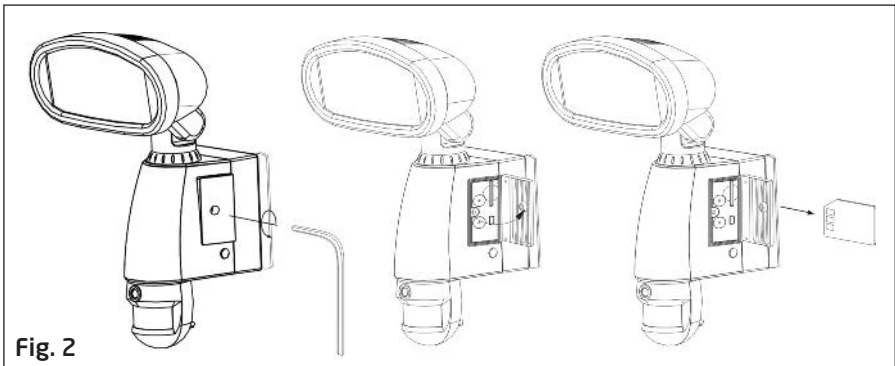

Fig. 2

Step 3 - Installing the GuardCam

IMPORTANT - IF IN ANY DOUBT ABOUT THE INSTALLATION OF THIS PRODUCT, CONSULT A QUALIFIED ELECTRICIAN

- This product must be grounded
- Do not mount the unit against inflammable surfaces
- The motion detector will not operate correctly if it is installed:
 - Near the outlet of a central heating boiler
 - Near air conditioning plant
 - Pointing directly at moving vehicles
 - Within sight of reflections from moving water
 - Where other lamps could shine on the detector

BEFORE ATTEMPTING ANY INSTALLATION OR MAINTENANCE, ENSURE THAT THE ELECTRICAL SUPPLY IS SWITCHED OFF AND THE CIRCUIT FUSES REMOVED OR THE CIRCUIT BREAKER IS IN THE OFF POSITION.

Please make sure the voltage and polarity are correct before connection. Incorrect voltage may cause electric shock. If you are not sure, please contact your retailer.

Note: It is recommend to mount GuardCam 2M above the ground for optimum performance, do not mount the fixture below 1.2M. See Fig. 3 for details of performance range.

Detection range: 10M x 160° (see Fig. 3)

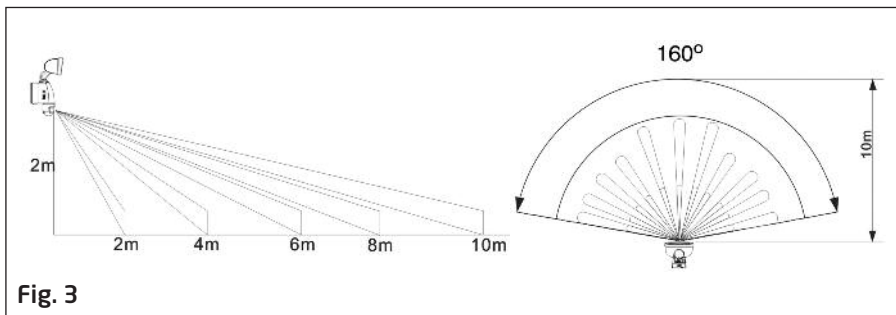

Step 4 - Mounting your GuardCam (see Fig. 4 & Fig. 5)

1. Place plastic masonry plugs into desired surface aligning holes as shown below. Using an electric screwdriver, fasten mounting plate directly to surface using screws E.
2. Feed the cable through the back mounting box and bush the cable entry to avoid abrasion to the cable.
3. Wire the unit as follows: (Ensure all wires are connected securely and that no loose strands are exposed)

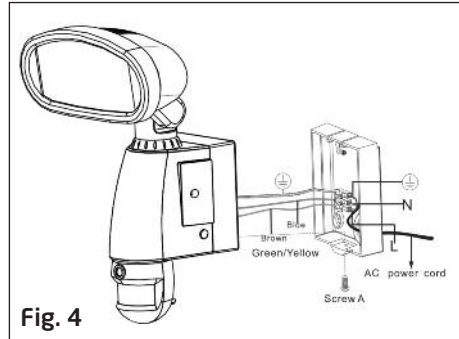
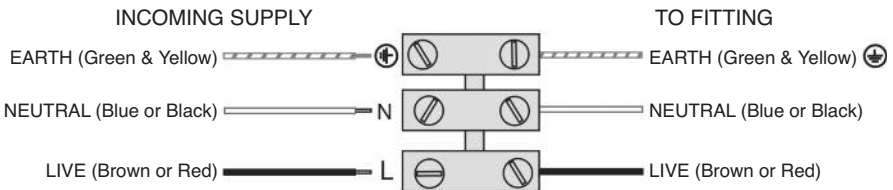

Fig. 4



4. Make sure the polarity is correct. Double check the connections after wiring. Errors may damage the motion sensor or cause a fire hazard.
5. Attach the unit to the mounting plate. You will first need to angle the unit back so that the catch at the top of the mounting plate fits into slot on the back of the unit. Next lower the unit until holes at the bottom of the mounting plate and unit are flush. Then screw (screw A) into this hole, tightening carefully.

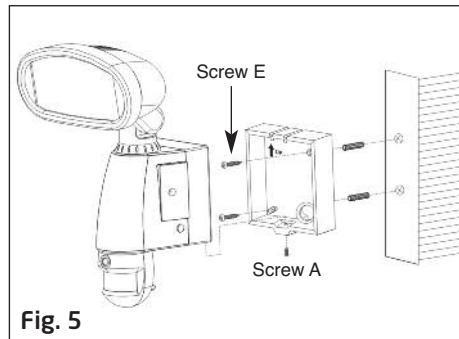

Fig. 5

Please allow 1 minute warm-up time after switching on.

- **Push the RESET button after switching on.**

Remove plastic lens cover from camera after installation. (see Fig. 6)

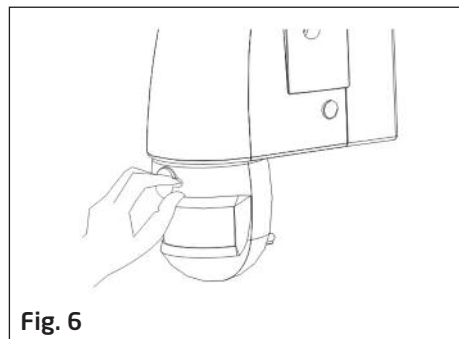
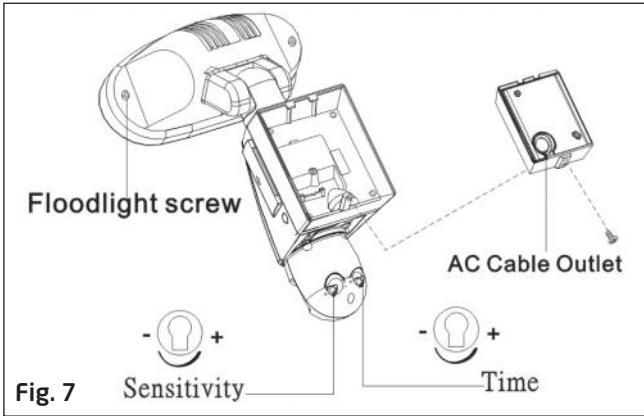

Fig. 6

Step 5 - Adjusting the Settings (see Figs. 7 - 9) ⁷

- **Time control:** Turn the time control knob to “+” side to increase the illumination time (7 minutes max.), turn the control knob to “-” side to reduce the illumination time (30 seconds min.)
- **Sensitivity control:** Adjust the detector range of Passive Infrared Motion Sensor (± 2M ~ 10M)



■ **Selecting working mode:**

Mode 1: Suggested setting when out of town

- Light + camera + speaker: all day detection
- Daytime and nighttime: light, camera and speaker are all in operation

Mode 2: Suggested for day to day use

- Light at night + camera all day + speaker in the daytime
- Daytime: light is off, camera is on, speaker is on
- Nighttime: light is on, camera is on, speaker is off.

Mode 3: Perfect for a place of business

- Light at night + camera all day + speaker at night
- Daytime: light is off, camera is on, speaker is off.
- Nighttime: light is on, camera is on, speaker is on.

■ **Audio mode:** for different sound selection

Pre-set default is “silent mode”, push one time for “ding-dong”, push again for “dog barking”. Push one more time for the message you just recorded.

■ **LED indicator:** for indicating the function status of the unit by different colour LED lights.

- 1) Red: SD card is not inserted into the SD slot or the system is malfunctioning.
- 2) Green: The unit is recording or USB is inserted and connecting with the computer
- 3) LED off: stand by (SD card is inserted into the slot), when off/record button is pressed.

- Please note when off/record button is pressed, remove SD card within 30 seconds (now the LED will turn red after SD card is removed from the slot)
- **Reset button:** restore functions to default settings
 - 1) Press RESET button once each time you turn on unit.
 - 2) Please press this button in case of system malfunction.
- **Off/Rec:** Please press Off/Rec button to remove SD card. Please remove card within 30 seconds of pressing the Off/Rec button to avoid loss of data.

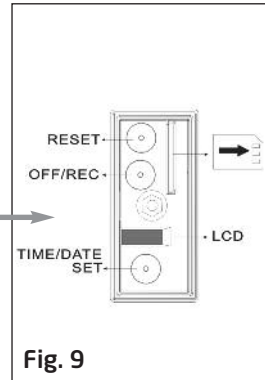
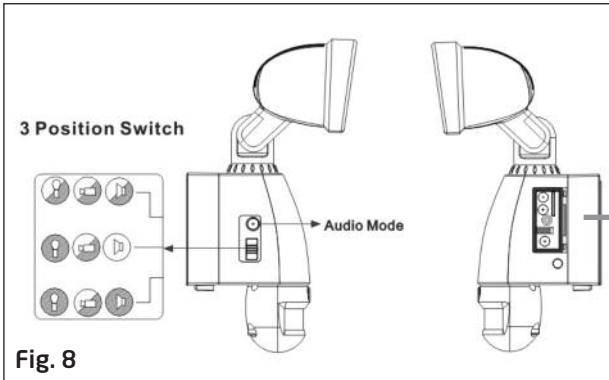



Step 6 - Set the Date and Time

This will allow the security video taken by GuardCam to display the correct date and time it was taken.

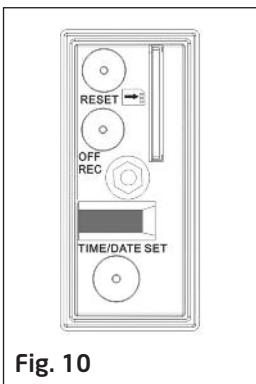
Push TIME/DATE SET button (see Fig. 10) for 3 seconds, The LCD screen will then flash 3 times, indicating you have entered Time/Date setting mode.



1. **"YEAR" setting:** "Y" and "08" are displayed on the screen; push the button to set year from "08-99", push the button again and hold for 3 seconds to scroll through numbers quickly. If you have not pressed the button for 3 seconds, it will automatically save the year and go on to allow you to set the month.
Repeat the same setting procedure for MONTH/DATE/HOUR/MINUTE.

2. **"VIDEO/PHOTO" setting:** when entering this mode, these two icons  and  and "V" appear on the screen ; push the button to choose "V" (Video) or "P" (Photo). If you have not pushed any buttons for 3 second, "OK" will appear on the screen, indicating it has automatically saved the current settings. The LCD screen will shut off automatically 10 seconds later.
- * On the "P" (photo) setting, GuardCam will take a series of digital photographs at a rate of 3 photos every second when the motion sensor is triggered.

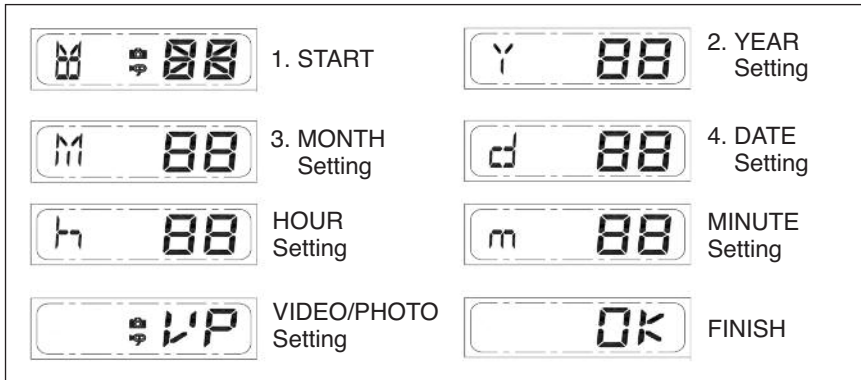

Step 7 - Viewing Video

Viewing image by computer through a card reader (see Fig. 11)

- Open the waterproofed cover on the GuardCam Motion Light with Video Camera
- Press OFF/REC button and remove SD card from the slot.
- Put the SD card into the card reader supplied, then insert the card reader into PC via a USB port and open Windows Media Player to view the video.

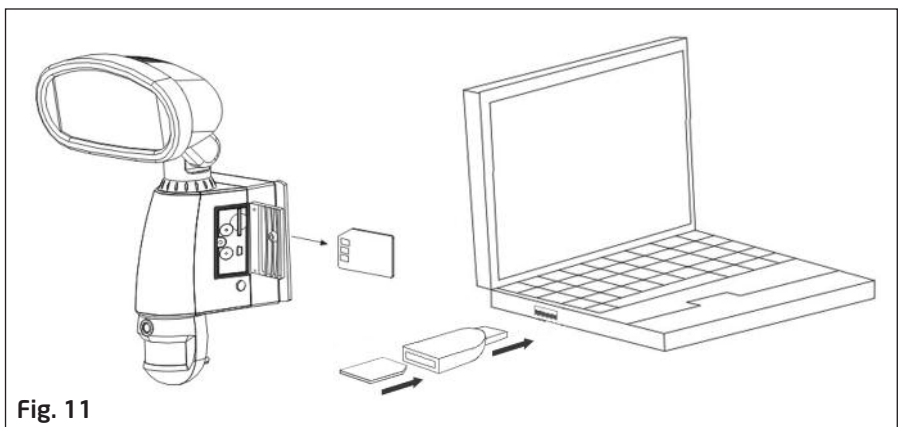

Technical Specifications

Features and specification:

- PIR detection angle 160 Deg and detection range up to 10M
- Records 20 seconds image recording for image stream : 10fps at 480*640 Pixels
- Built in SD card slot for SD memory card
- SD card slot for additional storage, max memory size up to 2G
- SD card specification: FAT
- Automatic exposure control, white balance and sharpness
- Auto Date & Time stamp
- Effective viewing angle : 60 deg
- Effective viewing distance: 8M
- Image format: JPEG AVI File
- Powered by AC 100V to 240V (subject to requirement)
- Halogen tube 230W
- Auto light sensor
- Sensitivity control
- Floodlight time delay control

General Information and Safety

SPECIAL CARE INSTRUCTIONS

- The GuardCam Motion Light with Video Camera is designed to be weather resistant. Never attempt to immerse the unit in water or any other liquid. This will damage the unit and void the warranty.
- This product is designed to illuminate, video, and make verbal announcements. It will not prevent the commission of any act, legal or illegal. The manufacturer assumes no liability for any damage to property, injury to person, or death.
- Use a soft lens cloth for cleaning lens. Avoid touching lens with fingers.
- Remove dirt or stains with a soft cloth dampened with water or neutral detergent. Keep the GuardCam Motion Light with Video Camera in a dry and cool dust-free environment or container when it is NOT used
- Do not open the GuardCam Motion Light with Video Camera for unauthorized service. This could cause serious damage to the unit and will void the warranty.
- This GuardCam Motion Light with Video Camera is a precision electronic device. Do not attempt to service this camera yourself, as opening or removing covers may expose you to the danger of electric shock or other risks.
- To avoid risk of burns due to high temperature do not touch the floodlight when it is turned on.

